

## Serec Process Flow Diagram and Description

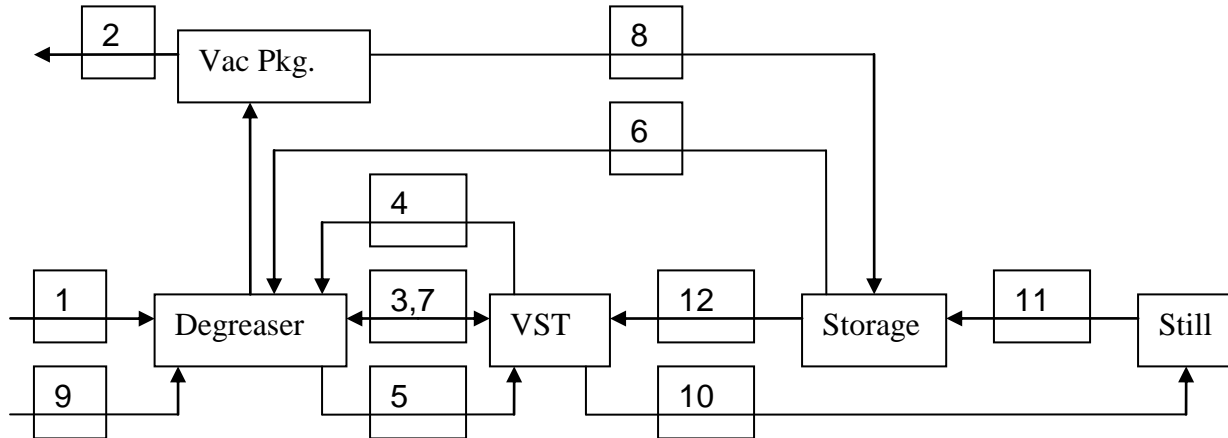

### Cleaning Process

1. Load parts chamber and close lid.
2. Evacuate air from process chamber to one torr and out of the unit using the vacuum package.
3. Equalize pressure between the degreasing chamber and the vapor supply tank.
4. Fill the degreaser with solvent from the vapor supply tank (VST) (submerge parts) and soak. May apply recirculation soak/flushing. Ultrasonic energy may be applied to enhance cleaning. (Optional). Also, basket rotation may be applied. (Optional)
5. Drain cleaning chamber and return solvent to the vapor supply tank. Note, steps 4 and 5 can be repeated as desired.(Optional)
6. Spray pure cold solvent from the storage tank. (Optional) Note, excess solvent is collected in the vapor supply tank.
7. Vapor degrease\heat parts with vapor from the vapor supply tank. Note, excess solvent is collected in the vapor supply tank.
8. Vacuum dry chamber and parts to one torr using the vacuum package.
9. Return chamber back to atmospheric pressure.

### Distillation Process

10. Contaminated solvent from the vapor supply tank is transferred to the distillation vessel on an as need basis.
11. Solvent is distilled and collected in the storage tank during the cleaning process cycle when the vacuum package is available. Distilled solvent is required to replenish the vapor supply level and supply pure solvent spray for the on coming cleaning cycle.
12. Removed contaminated solvent from the vapor supply tank is replenished by pure distilled solvent from the storage tank to maintain high solvent purity levels in the vapor supply tank.